

A LFANO



Tyrecontrol 

Manual (EN)

A1950

**Product Reference :**

A1950

Degree of precision :

0.01 Bar - 0.15 PSI

Units of measurement :

Bar/PSI

Maximal Pressure :

7 Bar/100 PSI

Backlighting :

LEDs

Power :

2xAA batteries

AIR:

CO² Cartridge

Data transfer :

Via cable

Specially designed for karting, the Tyrecontrol Air innovates by allowing you to read and record hot and cold pressures with a direct link to your Alfano 6.

Its innovative valve allows you to reduce but also increase pressures thanks to its air cartridge.

Doing so, you gain autonomy and control over your tyres and the ability to analyze their data in the Alfano 6 App.



Short and long push

Short Push



Long push



Pressure Setup



Real time reading of your pressure

Open the valve (anti-clockwise) allows you to add pressure.

The valve can be close by turning it clockwise

To reduce pressure, press on the button



The Tyrecontrol allows, thanks to its innovative valve, to use Air Cartridges (available in sport shop like Decathlon, cycling shop or website like Ebay or Amazon)

Warning : During cartridge replacement, it's imperative for the cartridge to be empty and the valve open. All actions outside the limits of this warning could result in injuries or damage on the device. The valve has to be closed when the cartridge is re-installed



Data Transfer



You can connect your Tyrecontrol Air to your Alfano 6 by using the (black) connector and the cable (ref : A2701 - not included)



Once connected, your Tyrecontrol Air will show the logo TRANSFER

Transfer the pressure as cold tyre pressure



Transfer the pressure as hot tyre pressure

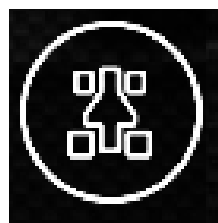

Once the data is transferred to your Alfano 6, you will find all the informations in your App by clicking on the "Session info" icon.

Alfano 6 App, available for free on Android, iOS and PC



Setup

The "Setup" menu is accessible by doing a long push on the On/Off button while turning on your Tyrecontrol Air



5 pages of setup are available on your Tyrecontrol Air :

Page 1 : unit selection Bar/Psi

Page 2 : type of vehicule (auto/moto)

Page 3 : setup for the first tyre selected

Page 4 : Off Set setup

This setting allows you to include an offset of a maximum of 0.2 Bar / 20 PSI. This type of setting is used in competition to modify on-screen information and mislead not informed personnel (competitors, technical spy, others...)

page 5 : Firmware version and serial number



Warning - Informations

Low Battery

In the case where your the batteries of your Tyrecontrol Air will be low, a BAt icon will appear right before your Tyrecontrol Air turns off

AA Batteries

The Tyrecontrol Air needs 2 AA batteries. To preserve a maximal autonomy, Alfano S.A. recommends using batteries.

Moreover, during long period of inactivity (several weeks), Alfano S.A. recommend to uninstal batteries to avoid any risk of leaks that could result in degradation of internal component of the Tyrecontrol Air.

CO² cartridges replacement

During the withdrawal of the used cartridge, it's imperative that the withdrawn cartridge is empty and the valve opened. All actions done without respecting these recommendations could deteriorate your device or create risks of injuries.

Before proceeding to the installation of the new cartridge, make sure to close the valve.

Alfano S.A. recommend adding a bit of lubricant (Vaseline) on the thread to preserve the thread of your Tyrecontrol Air. It's imperative to not put lubricant on the tip of the cartridge as it can deteriorate the pressure sensor.

CO² cartridges storage

Alfano S.A. recommend to stock CO² cartridge in accordance to distributor recommandations. A long exposure to sun or shipping by plane is not recommended.

These security rules explain why Alfano S.A. will not provide CO² cartridges for its customers.



Maintenance and repair

Repair kit



1) O-ring
CO² cartridge



2) O-ring valve



3) Valve seal
(special part)



Screw and washer to
replace the valve seal

Seals placement

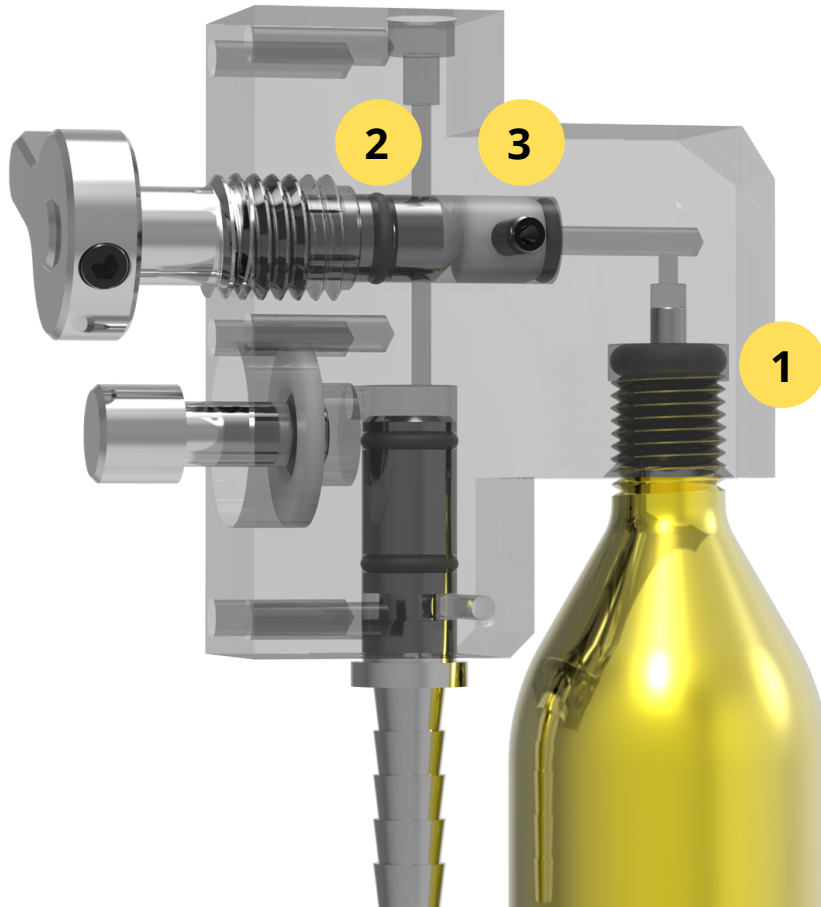

CO² cartridge seal replacement



This seal needs to be replaced if you notice a leak near the CO² cartridge.

Defective seal removal

Once the cartridge withdrawn in respect of security recommendation you can either :

- Remove the seal with needle nose pliers
- Pull out the seal by injecting compressed air with a blow gun

New seal install

Replace the new seal at the bottom of the designed emplacement for the CO² cartridge

Rotative valve seal replacement

This seal needs to be replaced if you notice a leak near the lever to add pressure

Defective seal removal

Once the cartridge uninstalled in respect of security rules, you can proceed to dismantle the top part of the lever (in open position). This operation can be done using a 2 mm Allen key

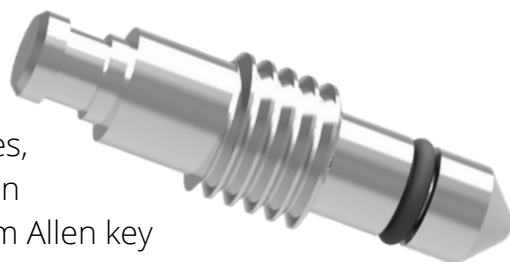

Once the top part is dismantled (lever), you can uninstall the rotating valve by unscrewing it by hand. This allows you to have a total access to the part to remove the defective seal.

To remove the defective seal, we recommend to withdraw it with needle nose pliers.

New seal install

Replace the new seal by introducing it in the specially designed groove. Following that step you will be able to reassemble your Tyrecontrol Air in accordance with the steps previously explained.



Maintenance and repair

Valve seal replacement

This seal needs to be replaced if a leak is noticed at the exit of the air pipe

Defective seal removal

Once the cartridge uninstalled in respect of security rules, you can proceed to dismantle the top part of the lever (in open position). This operation can be done using a 2 mm Allen key. Then, remove the rotation valve in accordance to instructions explained in the previous chapter.

Once removed, you can proceed to dismantle the batteries cover and the back cover by unscrewing the screws indicated here against in yellow

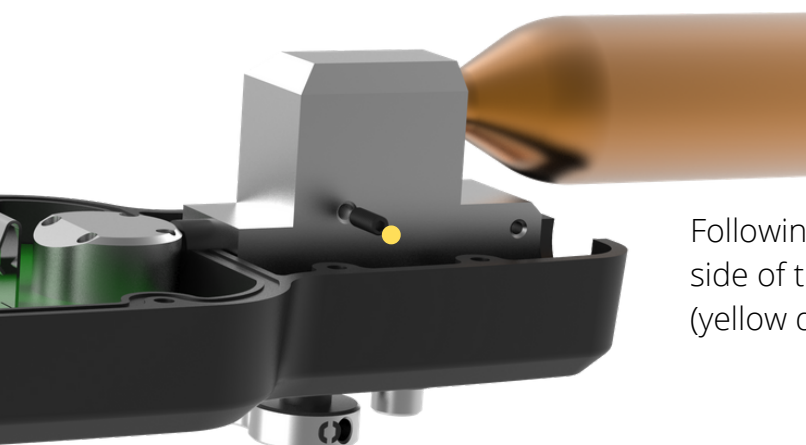

Following that step, unscrew the M3x8 screw on the side of the metallic part with a 1.5 mm Allen key (yellow dot on the image on the left)

Next, with the screw and washer provided, do a rotation as shown in the pictures under to remove the seal

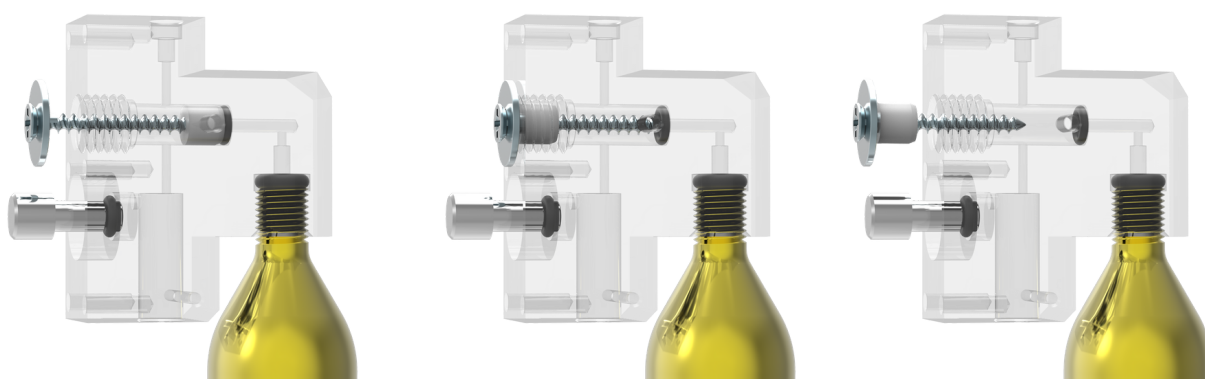

Maintenance and repair

New seal install

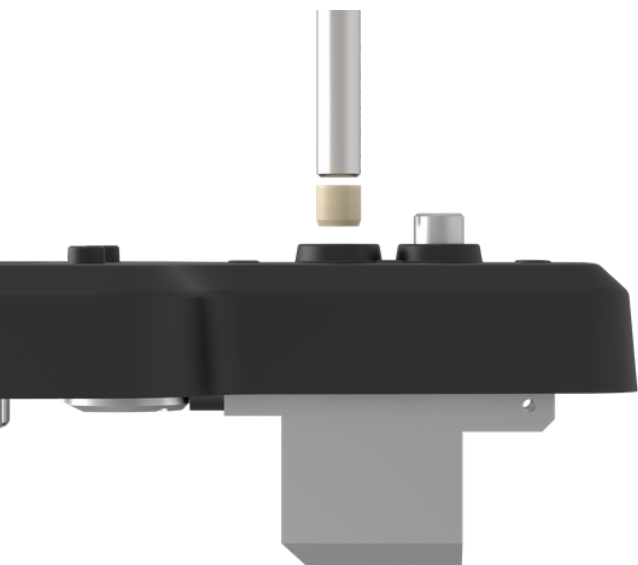

To place the new valve seal, place the seal at the entrance of the opening. The conical side needs to be orientated toward the interior.

With the help of a 7mm drill mounted upside down in a drill press (used as a press), press the new seal in its emplacement with caution

To reassemble, make sure to re-screw the valve by hand firmly as well as the lever to close the valve.

Then you can re-screw the M3x8 Allen screw on the side of the metallic part with a 1.5 mm key.



Warning : the screw need to remain 1mm out from the metallic surface (can be measured with sliding calliper)

Once all the internal parts reassembled, you can replace the back cover of the Tyrecontrol as well as the batteries and batteries cover with the screws previously unscrewed

Warning

During disassemble or reassemble of parts, make sure to not damage any mechanical or electronical parts.

For any questions or hesitations, do not hesitate to contact Alfano S.A. :

Rue de l'Industrie, 3B
B-1400 Nivelles (Belgique)
Phone: +32(0)67 410 846
Email : info@alfano.com

